



State of South Carolina Contribution Expenditure Report

This form is designed to collect the quarterly and annual expenditure reports required by South Carolina in accordance with Proviso 117.21 of the appropriations act and Executive Order 2022-19. This form must be submitted to the state agency that is providing the contribution to the designation organization at the end of year quarter and by June 30, 2024.

Contribution Information

Amount	State Agency Providing the Contribution	Purpose
--------	---	---------

Organization Information

Entity Name	Chesterfield County Sheriff's Office
Address	203 Watson Street
City/State/Zip	Chesterfield County Sheriff's Office
Website	www.chesterfieldsheriff.org
Tax ID#	
Entity Type	County

Organization Contact Information

Name	Cambo Streater
Position/Title	Sheriff
Telephone	
Email	

Reporting Period

Reporting Period	Quarter 2: October 1, 2023 - December 30, 2023
------------------	--

Accounting of how the funds have been spent:

Description <i>(Attach additional detail for subgrantees and affiliated nonprofits)</i>	Budget	Expenditures				Total	Balance
		Quarter 1	Quarter 2	Quarter 3	Quarter 4		
Performance Dodge - 2 Dodge Durango's	\$750,000.00		\$84,158.03			\$84,158.03	-\$84,158.03
Dana Safety Supply - Ammo 223 and 5.56			\$7,719.84			\$7,719.84	-\$7,719.84
Sinter Fire - 9mm 100 Grain Ammo			\$5,499.00			\$5,499.00	-\$5,499.00
Coppertop Gun Shop - 10 AR 15 Rifles, 10 Red Dot			\$5,858.78			\$5,858.78	-\$5,858.78
Tolson's Auto Sales - Ford F150			\$28,000.00			\$28,000.00	-\$28,000.00
Roundis - 16 Red Dot Optics for Pistols			\$4,960.00			\$4,960.00	-\$4,960.00
			\$0.00			\$0.00	\$0.00
Grand Total	\$750,000.00	\$0.00	\$136,195.65	\$0.00	\$0.00	\$136,195.65	\$613,804.35

Explanation of any unspent funds (to be provided only if unspent funds remain at the end of the fiscal year):

Expenditure Certification

The Organization certifies that the funds have been expended in accordance with the Plan provided to the Agency Providing the Distribution and for a public purpose.

Signature

C.L. Streater

Printed Name

Sheriff

Title

2/6/2024

Date

REQUISITION

TO: Purchasing Agent

County of Chesterfield
Administration - 178 Mill Street
Chesterfield, SC 29709
Phone: 843-623-2535

FROM: Sherry D

Dept. _____

- REQUEST FOR (check one)
- PURCHASE
 - PAYMENT
 - PRINTING (Attach Job Ticket)
 - OTHER _____
 - REIMBURSEMENT
 - APPROPRIATION TRANSFER
 - AS ATTACHED

Suggested Vendor's Name: Value Safety Supply

DATE: 12-27-23

Address: 1300 S. Main St. Chesterfield, SC 29709

Phone: _____

QUANTITY	CATALOG NUMBER	ITEM/SERVICE REQUIRED	PRICE	AMOUNT
1	TWINE 4500005	12 1/2" x 1/2" x 100' Yellow		\$496.50
2	TWINE 4500005	12 1/2" x 1/2" x 100' Yellow		\$357.40
3				
4				
5				
6				
7				
8				
9				
TOTAL				\$853.90

Complete all sections including full address, catalog numbers and price extensions. Incomplete requisitions will be returned. Allow 6-8 weeks for processing. Use back of form to record price quotes. Requisitions due in purchasing office the 15th of each month. Please pay from the following account:

Requested by: Michelle Kelly

Department's Authorized Signature _____

REQUISITION

TO: Purchasing Agent
 County of Chesterfield
 Administration - 178 Mill Street
 Chesterfield, SC 29709
 Phone: 843-623-2535

FROM: Shenoy Dept.

REQUEST FOR (check one)

- PURCHASE
- PAYMENT
- PRINTING (Attach Job Ticket)
- OTHER
- REIMBURSEMENT
- APPROPRIATION TRANSFER
- AS ATTACHED

DATE: 12-28-23

Suggested Vendor's Name: Dana Safety Supply

Address: P.O. Box 117297 Atlanta, GA 30308 - 7297

Phone: 800-845-0405 PO# 1004760

QUANTITY	CATALOG NUMBER	ITEM/SERVICE REQUIRED	PRICE	AMOUNT
1	Invoice # 885388	14 Glock 45 holsters		
2				
3				
4				
5				
6				
7				
8				
9				

TOTAL 12,101.68

Complete all sections including full address, catalog numbers and price extensions. Incomplete requisitions will be returned. Allow 6-8 weeks for processing. Use back of form to record price quotes. Requisitions due in purchasing office the 15th of each month.

Please pay from the following account:

100-421-100-899 Public Safety

Requested by: Dan [Signature]
 Department's Authorized Signature

REQUISITION

TO: Purchasing Agent
 County of Chesterfield
 Administration - 178 Mill Street
 Chesterfield, SC 29709
 Phone: 843-623-2535

FROM: Sheniff Dept.
 REQUEST FOR (check one)
 PURCHASE
 PAYMENT
 PRINTING (Attach Job Ticket)
 OTHER
 REIMBURSEMENT
 APPROPRIATION TRANSFER
 AS ATTACHED

DATE: 12-28-23

Suggested Vendor's Name: Shellback Tactical
 Address: 995 Holland Ave. Cayce, SC 29033-3627
 Phone: 859-473-1855 PO # 1004762

	QUANTITY	CATALOG NUMBER	ITEM/SERVICE REQUIRED	PRICE	AMOUNT
1	11		2-11 Level TV Body Armor for		
2			S&T Tolum		
3					
4					
5					
6					
7					
8					
9					

TOTAL 9,769.16

Complete all sections including full address, catalog numbers and price extensions. Incomplete requisitions will be returned. Allow 6-8 weeks for processing. Use back of form to record price quotes. Requisitions due in purchasing office the 15th of each month.

Please pay from the following account:
100-421-100-599 Public Safety

Requested by: [Signature]
 Department's Authorized Signature

Vaughn, Jennifer

From: Michelle Stanley <mstanley@chesterfieldcountysc.com>
Sent: Wednesday, February 7, 2024 3:57 PM
To: Vaughn, Jennifer
Subject: RE: Public Safety

That is the use tax on the Sinterfire invoice in the amount of \$5,499. They didn't charge tax.

From: Vaughn, Jennifer <jvaughn@chesterfieldsheriff.org>
Sent: Wednesday, February 7, 2024 2:57 PM
To: Michelle Stanley <mstanley@chesterfieldcountysc.com>
Subject: Public Safety

Could you tell me what was paid from the public safety money on 1-31-24 in the amount of \$431.12?

Jennifer Vaughn
Administrator
Chesterfield County Sheriff's Office
203 Watson Street
Chesterfield, SC 29709
Phone: 843-623-2101
Fax: 843-623-3534
Website: www.chesterfieldsheriff.org

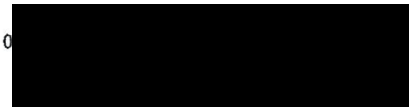

HEATHER FELTS

Purchasing Card

December

Cardholder Activity

Account Information	Payment Information	Account Summary
Mail Billing Inquiries to: BANKCARD CENTER PO Box 660441 Dallas, TX 75266-0441 TTY Hearing Impaired: Dial "711" Outside the U.S.: 1.509.353.6656 24 Hours For Lost or Stolen Card: 1.888.449.2273 24 Hours	Statement Date 12/31/23 Credit Limit \$2,000 Cash Limit \$0 Days in Billing Cycle 31 Total Activity \$869.11 <p style="text-align: center;">THIS IS NOT A BILL - DO NOT PAY</p>	Credits \$0.00 Cash \$0.00 Purchases \$869.11 Other Debits \$0.00 Cash Fees \$0.00 Other Fees \$0.00 Total Activity \$869.11

Important Messages

Global Card Access - your card information whenever, wherever and however you need it. From the dashboard, you can quickly check your credit limit, balance, available credit and recent card activity. Other features like View PIN, Change PIN, Lock Card and Alerts help you keep your card secure. For added convenience, you can easily view or download your current statement up to 12 months of past statements. Visit www.bofa.com/globalcardaccess to register your card and start using Global Card Access today.

Transactions

Posting Date	Transaction Date	Description	Reference Number	MCC	Charge	Credit
12/05	12/04	SCDOR DORWAY	844-898-8542 SC	9311	779.92	
12/12	12/11	LYNCHES RIVER ELECTRIC C	LYNCHESRIVER.SC	4900	89.19	



Account Number: [Redacted]
 December 01, 2023 - December 31, 2023

Total Activity \$869.11

BANK OF AMERICA
 PO BOX 15731
 WILMINGTON, DE 19886-5731

Cardholder Signature _____ Date _____

HEATHER FELTS
 CHESTERFIELD COUNTY
 178 MILL ST
 CHESTERFIELD, SC 29709-1215

Manager Signature _____ Date _____

Transaction Receipt from SCDOR DORWAY

SCDOR DORWAY <noreply@gge4mailer.com>

Mon 12/4/2023 1:51 PM

To:hfelts@chesterfieldcountysc.com <hfelts@chesterfieldcountysc.com>

First Data Payment Confirmation

Order Information

Quantity	Item	Unit	Price
1	SCDOR TAX Payment	779.92 USD	779.92
	Shipping	USD	0.00
	Tax	USD	0.00
	Duty	USD	0.00
	Total	USD	779.92

This order is now complete. Transaction approved!

Here is your receipt:

===== TRANSACTION RECORD =====

SCDOR DORWAY
300A OUTLET POINTE BLVD.
COLUMBIA, SC 29210
United States
HTTPS://DOR.SC.GOV

TYPE: Purchase

ACCT: Visa \$ 779.92 USD

CARDHOLDER NAME : Heather Felts
CARD NUMBER : ##
DATE/TIME : 04 Dec 23 13:51:40
REFERENCE # : 001 0408160 M
AUTHOR. # : 049405
TRANS. REF. : 3748322

Approved - Thank You 100

Please retain this copy for your records.

Cardholder will pay above amount to
card issuer pursuant to cardholder
agreement.

=====

This is not a valid receipt until funds have been received by the SCDOR. Credit card payments may take up to three days to process. If your payment is declined, you will receive a bill from the SCDOR.

CHESTERFIELD COUNTY COUNCIL

CREATE USE TAX VOUCHER

FY 2023-2024

PRINT ONLY

11/01/2023 TO 11/30/2023

VO#	VENDOR NUMBER/ NAME	CHECK#	DATE	TAXABLE AMOUNT	TX	STATE TAX	LOCAL1	LOCAL2	DISC	TOTAL TAX
100-415-210-610 GENERAL SUPPLIES										
181375	4657 NORMA JORDAN	126995	11/08/23	132.28	2	0.00	0.00	1.32	0.03	1.29
				<u>132.28</u>		<u>0.00</u>	<u>0.00</u>	<u>1.32</u>	<u>0.03</u>	<u>1.29</u>
100-421-100-742 VEHICLES										
181643	2203 GRIFFIN CHRYSLER DOI	127090	11/17/23	612.75	2	0.00	0.00	6.13	0.12	6.01
				<u>612.75</u>		<u>0.00</u>	<u>0.00</u>	<u>6.13</u>	<u>0.12</u>	<u>6.01</u>
100-421-100-899 STATE:LEO - LIFE SAFETY FUNDS EXP										
181720	3049 SINTERFIRE, INC.	127113	11/21/23	5,499.00	Y	329.94	54.99	54.99	8.80	431.12
				<u>5,499.00</u>		<u>329.94</u>	<u>54.99</u>	<u>54.99</u>	<u>8.80</u>	<u>431.12</u>
100-421-200-866 PRISONER EXPENSE/MEDICINE/CLOTHES										
181587	2451 CHARM-TEX	127060	11/16/23	276.17	Y	16.57	2.76	2.76	0.44	21.65
				<u>276.17</u>		<u>16.57</u>	<u>2.76</u>	<u>2.76</u>	<u>0.44</u>	<u>21.65</u>
100-422-500-610 GENERAL SUPPLIES										
181290	1476 SUNBELT DISTRIBUTION	126967	11/07/23	181.75	Y	10.91	1.82	1.82	0.29	14.26
181291	1476 SUNBELT DISTRIBUTION	126967	11/07/23	347.35	Y	20.84	3.47	3.47	0.56	27.22
				<u>529.10</u>		<u>31.75</u>	<u>5.29</u>	<u>5.29</u>	<u>0.85</u>	<u>41.48</u>
GRAND TOTAL				<u>7,049.30</u>		<u>378.26</u>	<u>63.04</u>	<u>70.49</u>	<u>10.24</u>	<u>501.55</u>
STATE TAXABLE AMOUNT				<u>6,304.27</u>						
LOCAL TAXABLE AMOUNT				<u>6,304.27</u>						



200 Industrial Park Road

Commercial Invoice

Date	Invoice #
11/11/2023	9471

Bill To:
 Chesterfield County Sheriff's Office
 109 Scotch Road
 Chesterfield, SC 29709

Ship To:
 Chesterfield County Sheriff's Office
 109 Scotch Road
 Chesterfield, SC 29709

P.O. Number	Terms	Ship	Via	F.O.B.	Project
Email 30OCT2023	NET 30	11/11/2023	UPS Ground		

Quantity	Item Code	Description	Price Each	Amount
12,000	SF9100GL(LP)	9mm 100 Grain Frangible LF Rev: 8/2/20 Customer PO: Email 30OCT2023 Sales Order: 23329 SO Line: 001	0.442	5,304.00
1	Shipping & Handling Fee	Shipping & Handling Fee Rev: Customer PO: Email 30OCT2023 Sales Order: 23329 SO Line: 002	195.00	195.00

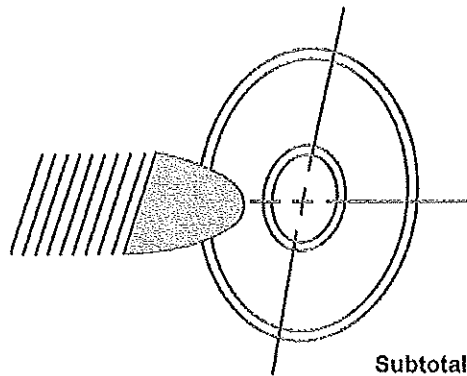

Subtotal \$5,499.00

Federal Excise Tax (11.0%) \$0.00

Invoices not paid in 30 days are subject to a 2% per month late charge.

Credit card payments will incur a 3.5% fee. This fee will be added at the time of payment.

Total	\$5,499.00
--------------	-------------------

Phone # 014-885-6672

Fax # 014-885-6673

abrennan@sinterfire.com

sinterfire.com

Date Received in Council Office:

Due Date:
ASAP

CHECK REQUEST

CHESTERFIELD COUNTY, SOUTH CAROLINA

DATE: 1-2-2024

PAYABLE TO:

Bank of America

ADDRESS:

PO Box 15731

Wilmington, DE 19886-5731

DESCRIPTION:

see next page

ACCOUNT NUMBER:

AMOUNT REQUESTED:

Public Safety 100-

Comm 100-

GS 100-

Uniform 100-

T&T 100-



\$ 867.33 ^{Credit} -.01 = \$ 867.32

\$ 37.79

\$ 500.82 + \$ 155.35 + \$ 1,597

234.72 ^{Awards} ^{Bank} ^{Toy} ^{Drive}

\$ 525.00

Total Check Amount Requested: \$ 3,918.15

REQUESTED BY:

Department's Authorized Signature

Request Approved By:

Finance Director:

County Administrator:

PURCHASING CARD LOG

DATE	VENDOR	AMOUNT	ACCOUNT NUMBER	DESCRIPTION OF PURCHASES
12-1	North American	\$ 807.33	100-421-100-899	Tourmiquets, Deputies & Supply
12-2	Amazon	\$ 37.79	100-421-100-520	Cm charger - 800 Radio
12-5	Wal-mart	\$ 26.20	ck#	Food - Awards Banquet
12-6	Amazon	\$ 234.72	100-421-100-254	Mechanical Sights - AR
12-8	N. American	\$.01 credit	100-421-100-899	
12-11	PSI	\$ 175.00	100-421-100-252	Aircraft Test - Drone - B. Reberg
12-11	PSI	\$ 175.00	100-421-100-252	Aircraft Test - Drone - C. Siler
12-12	WCS	\$ 123.82	ck#	Hams - Awards Banquet
12-13	Pee Dee Supply	\$ 9.01	100-421-100-610	Keys - C. Tyler evidence
12-14	Amazon	\$ 20.51	100-421-100-610	Keyboard & Mouse - T. Timney
12-14	Pinky Biggy	\$ 5.33	ck#	Food - Awards Banquet
12-14	Tractor Supply	\$ 28.36	100-421-100-610	Surge Protector - office clamps - Building 3
12-17	Tractor Supply	\$ 9.69	100-421-100-610	Zip ties
12-18	Harbor Freight	\$ 41.35	100-421-100-610	Zip ties, wire, blades, screwdrivers & tape
12-19	USPS	\$ 132.00	100-421-100-610	Stamps - Mail going out
12-20	Bethune Discard	\$ 400.00	ck#	Tons - Toy Drive - \$ Donated
12-20	Dollar Tree	\$ 78.31	ck#	Tons - Toy Drive - \$ Donated
12-21	PSI	\$ 175.00	100-421-100-252	Aircraft Test - Drone - J. Carnes
12-20	Wal-mart	\$ 1,118.84	ck#	Tons - Toy Drive - \$ Donated
12-27	Live View	\$ 259.90	100-421-100-610	Batteries for GPS units

ck



SHERIFF OFFICE
CHESTERFIELD COUNTY

Purchasing Card

December 01, 2023 - December 31, 2023

Cardholder Activity

Account Information	Payment Information	Account Summary
Mail Billing Inquiries to: BANKCARD CENTER PO Box 660441 Dallas, TX 76286-0441 TTY Hearing Impaired: Dial "711" Outside the U.S.: 1.509.353.6656 24 Hours For Lost or Stolen Card: 1.888.449.2273 24 Hours	Statement Date 12/31/23 Credit Limit \$10,000 Cash Limit \$0 Days in Billing Cycle 31 Total Activity \$3,918.15 THIS IS NOT A BILL - DO NOT PAY	Credits -\$0.01 Cash \$0.00 Purchases \$3,918.16 Other Debits \$0.00 Cash Fees \$0.00 Other Fees \$0.00 Total Activity \$3,918.15

Important Messages

Global Card Access - your card information whenever, wherever and however you need it. From the dashboard, you can quickly check your credit limit, balance, available credit and recent card activity. Other features like View PIN, Change PIN, Lock Card and Alerts help you keep your card secure. For added convenience, you can easily view or download your current statement up to 12 months of past statements. Visit www.bofa.com/globalcardaccess to register your card and start using Global Card Access today.

Transactions

Posting Transaction							
Date	Date	Description	Reference Number	MCC	Charge	Credit	
12/04	12/01	NORTH AMERICAN RESCUE LL GREER SC	24941663335083749407663	5047	867.33		
12/04	12/02	AMZN Mktp US*AQ61P2C33 Amzn.com/billWA	24692163336100199991094	5942	37.79		
12/06	12/05	WAL-MART #0642 CHERAW SC	24465013339141001024394	5411	26.20		
12/07	12/06	AMZN Mktp US*64TD6R13 Amzn.com/billWA	24692163340103605061886	5942	234.72		
12/11	12/08	NORTH AMERICAN RESCUE LL 8649664089 SC	74941663342083001023170	5047		0.01	
12/12	12/11	PSI SERVICES LLC 818-847-6180 CA	24492153345715113206808	8299	175.00		
12/12	12/11	PSI SERVICES LLC 818-847-6180 CA	24492153345745112302886	8299	175.00		
12/13	12/12	KJS MARKET IGA - PE PAGELAND SC	24427333346720229642828	5411	123.82		
12/15	12/13	PEE DEE SUPPLY CHESTERFIELD SC	24269793348500612518692	5261	9.01		
12/15	12/14	AMZN Mktp US*KY6YG00G3 Amzn.com/billWA	24692163348100788999660	5942	20.51		
12/15	12/14	PIGGLY WIGGLY 39 CHESTERFIELD SC	24137463349600245592582	5411	5.33		

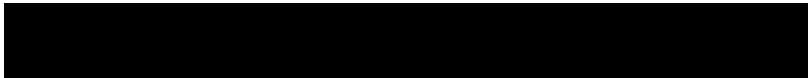

Account Number: [REDACTED]
December 01, 2023 - December 31, 2023

Total Activity \$3,918.15

BANK OF AMERICA
PO BOX 15731
WILMINGTON, DE 19886-5731

SHERIFF OFFICE
CHESTERFIELD COUNTY
178 MILL ST
CHESTERFIELD, SC 29709-1215

Cardholder Signature _____ Date _____

Manager Signature _____ Date _____

Posting payments: Payments received by mail at the remittance address shown on the Payment Coupon portion of the face of this statement on a banking day will be posted to your account on the day received. If we receive your mailed payment on a non-banking day, we will post it to your account on the next banking day. There may be a delay of up to 5 banking days in posting payments made at a location other than the mailing address listed on the front of your payment coupon.

Service for the hearing impaired (TTY/TDD): We accept calls made through relay services (dial 711).

Telephone monitoring: For the purposes of monitoring and improving the quality of service, Bank's supervisory personnel may listen to and/or record telephone calls between Bank employees and any person acting on Company's behalf.

In case of errors or questions about your bill: Errors or questions about your bill must be received in writing no later than 60 days after we sent you the first statement on which the error or problem appeared. Please mail this information to BANKCARD CENTER, PO BOX 660441, DALLAS, TX 75266-0441. Your letter must include the following information:

- The company name, cardholder name and account number in question.
- The dollar amount of the suspected error.
- A written description of the error and why you believe there is an error. If you need more information, describe the item you are unsure about.

Customer Service:	For questions regarding transactions, general assistance, and reporting lost and stolen cards, call:	
	<u>Within the U.S.</u> 1.888.449.2273	<u>Outside the U.S.</u> 1.509.353.6656 (collect calls accepted)

Thank you for your business.

Posting payments: Payments received by mail at the remittance address shown on the Payment Coupon portion of the face of this statement on a banking day will be posted to your account on the day received. If we receive your mailed payment on a non-banking day, we will post it to your account on the next banking day. There may be a delay of up to 5 banking days in posting payments made at a location other than the mailing address listed on the front of your payment coupon.

SHERIFF OFFICE
 CHESTERFIELD COUNTY
 XXX [REDACTED]
 December 01, 2023 - December 31, 2023

Transactions

Posting Transaction							
Date	Date	Description	Reference Number	MCC	Charge	Credit	
12/15	12/14	TRACTOR SUPPLY #2646 PAGELAND SC	24137463349001745485866	5599	28.36		✓
12/19	12/17	TRACTOR SUPPLY #2722 HARTSVLLE SC	24137463353001795327839	5599	9.69		✓
12/19	12/18	HARBOR FREIGHT TOOLS3202 HARTSVILLE SC	24231683353091010622146	5251	41.35		✓
12/20	12/19	USPS PO 4516000941 CHESTERFIELD SC	24137463354001844472098	9402	132.00		✓
12/21	12/20	BETHUNE DISCOUNT FOODS BETHUNE SC	24040683354900011700794	5411	400.00		✓
12/21	12/20	DOLLAR TREE CHERAW SC	24445003355001192097406	5331	78.31		✓
12/22	12/21	PSI SERVICES LLC 818-847-8180 CA	24492153355716834466282	8299	175.00		✓
12/22	12/20	WAL-MART #0842 CHERAW SC	24455013355141001330089	5411	1,118.84		✓
12/28	12/27	LIVE VIEW GPS 661-294-6805 CA	24493983361207835300044	4816	259.90		✓

SHERIFF OFFICE
CHESTERFIELD COUNTY

X [REDACTED]
December 01, 2023 - December 31, 2023
Page 4 of 4

Date Received in Council Office

Due Date: 2-9-2024

CHECK REQUEST
CHESTERFIELD COUNTY, SOUTH CAROLINA

DATE: 1-26-2024

PAYABLE TO: Sign Press

ADDRESS: 35 Fred Davis One Road
Cheraw, SC 29520

DESCRIPTION: Decal Sets - K-9 (\$309.00 + \$309.00)
Durango's

Public Safety
S →

ACCOUNT NUMBER:	AMOUNT REQUESTED:
100-421-100-899	\$309.00
100-421-100-899	\$309.00

Total Check Amount Requested: \$ 618.00

REQUESTED BY: [Signature]
Department's Authorized Signature



Request Approved By:

Finance Director:

County Administrator:

Date Received in Council Office:

Due Date:
ASAP

CHECK REQUEST
CHESTERFIELD COUNTY, SOUTH CAROLINA

DATE: 2-13-2024

PAYABLE TO: SC Department of Administration

ADDRESS: Office of Internal Operations
1200 Senate St., Suite 409
Columbia, SC 29201

DESCRIPTION: 2014 Chev. Express Van - Coroner's Office

Public Safety

ACCOUNT NUMBER: 100-4[REDACTED] AMOUNT REQUESTED: \$ 29,000.00

Total Check Amount Requested: \$ 29,000.00

REQUESTED BY: *[Signature]*
Department's Authorized Signature

Request Approved By:

Finance Director: _____

County Administrator: _____

Date Received in Council Office:

Due Date: ASAP

CHECK REQUEST
CHESTERFIELD COUNTY, SOUTH CAROLINA

DATE: 3-5-2024

PAYABLE TO: Dept. of Administration

ADDRESS: Office of Internal Operations
1200 Senate St., Suite 409
Columbia, SC 29201

DESCRIPTION: 2019 Chev. Tahoe - Sheriff

Public Safety

ACCOUNT NUMBER: 100-4[REDACTED] AMOUNT REQUESTED: \$ 25,000.00

Total Check Amount Requested: \$ 25,000.00

REQUESTED BY: *[Signature]*
Department's Authorized Signature

Request Approved By:

Finance Director: _____

County Administrator: _____

3-5-24 @ 3:37 pm

REQUISITION

TO: Purchasing Agent
County of Chesterfield
Administration - 178 Mill Street
Chesterfield, SC 29709
Phone: 843-623-2535

FROM: Sheniff **Dept.**

REQUEST FOR (check one)
 PURCHASE
 PAYMENT
 PRINTING (Attach Job Ticket)
 OTHER _____
 REIMBURSEMENT
 APPROPRIATION TRANSFER
 AS ATTACHED

DATE: 3-5-2024

Suggested Vendor's Name: Craig's Firearms
Address: 8761 Chapman Highway Knoxville, TN 37920
Phone: PO #1004866

	QUANTITY	CATALOG NUMBER	ITEM/SERVICE REQUIRED	PRICE	AMOUNT
1		Invoice # 42710	10 Glocks 43LE		3,461.40
2					
3		Invoice # 42596	12 Glocks 48		4,625.42
4					
5		Invoice # 42663	14 Glock 45LE		7,567.56
6					
7					
8					
9					
				TOTAL	\$15,654.38

Complete all sections including full address, catalog numbers and price extensions. Incomplete requisitions will be returned. Allow 6-8 weeks for processing. Use back of form to record price quotes. Requisitions due in purchasing office the 15th of each month.

Please pay from the following account:
100-421-100-899 Public Safety \$

Requested by: [Signature]
Department's Authorized Signature

Date Received in Council Office:

Due Date:
ASAP

CHECK REQUEST

CHESTERFIELD COUNTY, SOUTH CAROLINA

DATE: 3-6-24

PAYABLE TO: Bank of America

ADDRESS: PO Box 15731
Wilmington, DE 19886-5731

DESCRIPTION: See next page.

Helmets

ACCOUNT NUMBER:	AMOUNT REQUESTED:
Jail 188 100-421-1010	\$ 77.64
100-421-1010	\$ 442.60
comm. 100-421	\$ 75.58
Tech 100-421	\$ 2,235.60
Vehicle 100-421	83.66
T&T 100-421	487.24
Public Safety 100-421	\$ 2,226.96
DV Mgmt 451-421	\$ 359.92
Total Check Amount Requested: \$ 5,995.26	

REQUESTED BY: *D. Ol*
Department's Authorized Signature

Request Approved By:

Finance Director:

County Administrator:

PURCHASING CARD LOG

DATE	VENDOR	AMOUNT	ACCOUNT NUMBER	DESCRIPTION OF PURCHASES
1-31	Amazon	\$ 345.59	100-421-100-610	Ice Machine
2-1	Amazon	\$ 1,242.00	100-421-100-340	Car chargers - laptops - issues w/ others causing damage
2-1	Amazon	\$ 993.60	100-421-100-340	Car chargers - laptops
2-1	NAEMT	\$ 40.00	100-421-100-252	Course Fed - JB, Nathan, Greg + George
2-2	BoTack	\$ 2,226.96	100-421-100-899	Helmets - SMT Team
2-4	Amazon	\$ 15.11	100-421-100-742	Razors - Sticker removal on cars
2-8	CMC	\$ 17.22	100-421-100-742	Sealant, nuts for vehicles
2-9	SP Proclip	\$ 75.58	100-421-100-530	Clips for Sheriff's Tahoe
2-10	Amazon	\$ 10.75	100-421-100-742	wire coupler for siren box
2-14	SCVAN	\$ 406.58	100-421-100-252	Legist. S. Luther VA Conference - Victim's Rights week
2-14	Amazon	\$ 155.28	100-421-100-610	lock - Marc (Jail + 1 Supply)
2-15	Amazon	\$ 26.99	100-421-100-742	Front bumper cover - T. Timmy vehicle
2-15	Amazon	\$ 19.43	100-421-100-610	Label Maker Tape
2-16	Advance	\$ 13.59	100-421-100-742	Female Disconnect for upfitting cars
2-22	SCVAN	\$ 406.58	100-421-100-252	Legist. N. Gainey - VA Conf. - Victim's Rights week
				156-421-900-252

H8
 Tech
 Tech
 TET
 Public Safety
 Veh.
 Veh.
 Comm
 Veh.
 TET
 H8
 Vehicle
 H8
 Veh.
 Grant
 TET



SHERIFF OFFICE
CHESTERFIELD COUNTY

Purchasing Card

February 01, 2024 - February 29, 2024

Cardholder Activity

Account Information	Payment Information	Account Summary
Mail Billing Inquiries to: BANKCARD CENTER PO Box 660441 Dallas, TX 75266-0441 TTY Hearing Impaired: Dial "711" Outside the U.S.: 1.509.353.6656 24 Hours For Lost or Stolen Card: 1.888.449.2273 24 Hours	Statement Date 02/29/24 Credit Limit \$10,000 Cash Limit \$0 Days In Billing Cycle 29 Total Activity \$5,995.26 THIS IS NOT A BILL - DO NOT PAY	Credits \$0.00 Cash \$0.00 Purchases \$5,995.26 Other Debits \$0.00 Cash Fees \$0.00 Other Fees \$0.00 Total Activity \$5,995.26

Important Messages

Global Card Access - your card information whenever, wherever and however you need it. From the dashboard, you can quickly check your credit limit, balance, available credit and recent card activity. Other features like View PIN, Change PIN, Lock Card and Alerts help you keep your card secure. For added convenience, you can easily view or download your current statement up to 12 months of past statements. Visit www.bofa.com/globalcardaccess to register your card and start using Global Card Access today.

Transactions

Posting Transaction							
Date	Date	Description	Reference Number	MCC	Charge	Credit	
02/01	01/31	AMZN Mkt US*R22N21ZB2 Amzn.com/billWA	24692164031106206389152	5942	345.59 ✓		
02/02	02/01	AMZN Mkt US*R229V4CP1 Amzn.com/billWA	24692164032107263403885	5942	1,242.00 ✓		
02/02	02/01	AMZN Mkt US*R23WD7C41 Amzn.com/billWA	24692164032107263406161	5942	993.60 ✓		
02/02	02/01	NAEMT 601-924-7744 MS	24492154033852456356943	8249	40.00 ✓		
02/05	02/02	BOTACH INC 702-7031299 NV	24755424033640335975606	5999	2,226.98 ✓		
02/07	02/06	AMZN Mkt US*RB78024F2 Amzn.com/billWA	24692164037101055315873	5942	15.11 ✓		
02/09	02/08	CMC BUILDING SUPPLY CHERAW SC	24103904039900011300271	5211	17.22 ✓		
02/12	02/09	SP PROCLIP USA WWW.PROCLIPUSWI	24492164040000049153845	5734	75.58 ✓		
02/12	02/10	AMZN Mkt US*RB6784J61 Amzn.com/billWA	24692164041101465456477	5942	10.75 ✓		
02/15	02/14	SCVAN* REGM8CP7X4 WWW.SCVAN.ORGSC	2400077404500004813975	7399	406.58 ✓		
02/15	02/14	AMAZON.COM*R17R95S70 SEATTLE WA	24431064045003340427549	5942	155.20 ✓		

cl

00000000 00000000 00000000 47

Account Number: [REDACTED]
February 01, 2024 - February 29, 2024

Total Activity \$5,995.26

BANK OF AMERICA
PO BOX 15731
WILMINGTON, DE 19886-5731

Cardholder Signature _____ Date _____

SHERIFF OFFICE
CHESTERFIELD COUNTY
178 MILL ST
CHESTERFIELD, SC 29709-1215

Manager Signature _____ Date _____

SHERIFF OFFICE
CHESTERFIELD COUNTY

February 01, 2024 - February 29, 2024

Page 3 of 4

Transactions

Posting Transaction							
Date	Date	Description	Reference Number	MCC	Charge	Credit	
02/16	02/15	AMZN Mktp US*RI1UX61C2 Amzn.com/billWA	24692164046105055348684	5942	26.99 ✓		
02/16	02/15	AMZN Mktp US*RI00857H0 Amzn.com/billWA	24692164046105069120590	5942	19.43 ✓		
02/19	02/16	ADVANCE AUTO PARTS #0421 CHESTERFIELD SC	24326884048042000027219	5533	13.59 ✓		
02/23	02/22	SCVAN* REG610FSAGH WWW.SCVAN.ORGSC	24000774053000006901967	7399	406.88 ✓		<i>al</i>